

机电安装工程的消声减振，全面总结

机电安装工程的消声减振对象包括设备和管道两方面，既要防止包括制冷机组、空调机组、水泵、风机等设备产生较大振动和噪声，也要防止管道传播设备及自身产生的振动和噪声。本文从设施及工艺两个方面，总结了机电安装工程在水泵、空调机组、排风排烟机组、冷冻机组、管道各专业上的常用消声减振做法。

一、消声减振设施



自立式弹簧隔振器



限位式弹簧隔振器



防振吊钩



聚氯丁橡胶水管柔性接头



不锈钢水管柔性接头/连接器



防振垫片



消声止回阀



管路 DT 型减振器

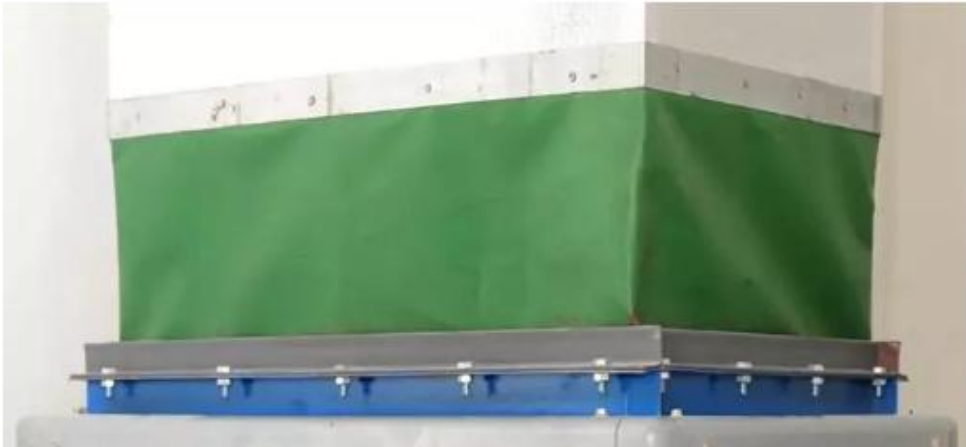

风管柔性接头

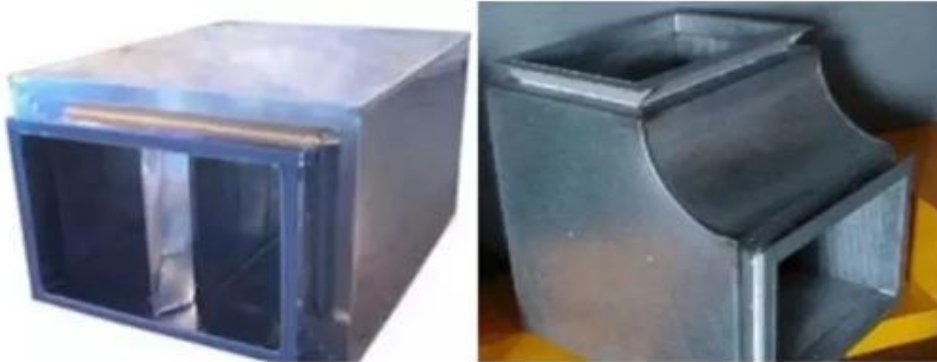

消声器或者消声静压箱

二、消声减振工艺

1. 水泵消音隔振处理

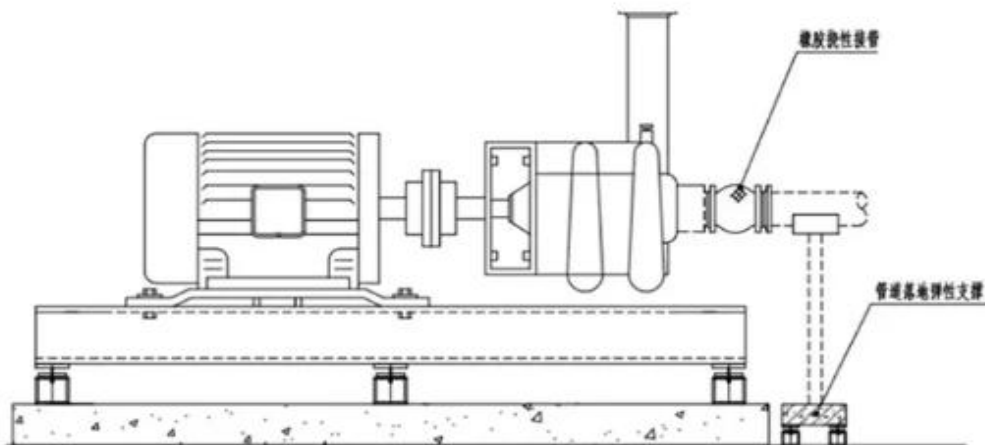

卧式水泵隔振处理图

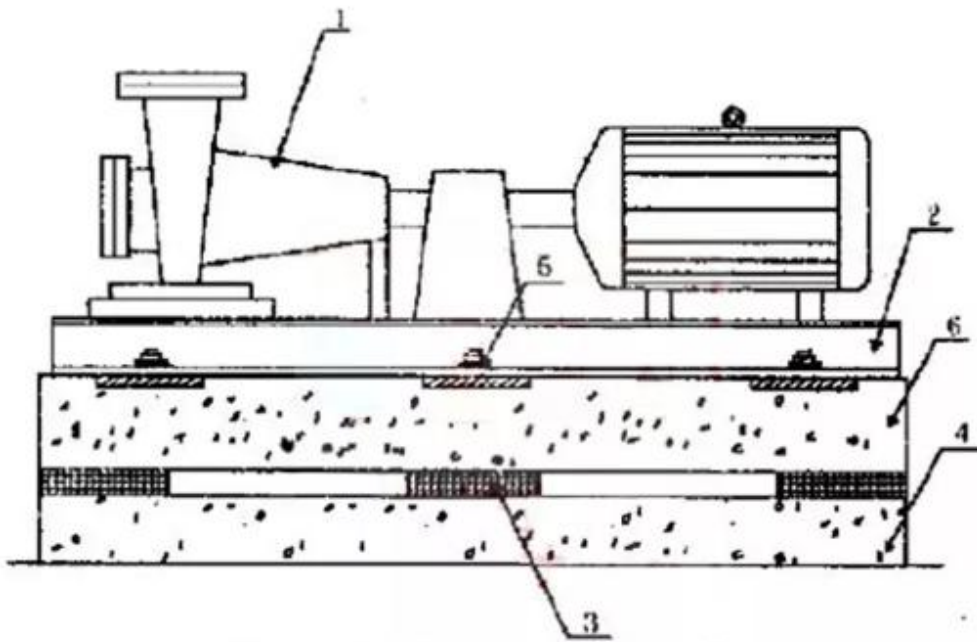

1. 水泵；2. 水泵自带槽钢支架；3. 橡胶减震垫；4. 水泵基础（高度>50nm）；5. 预埋钢板；6. 混凝土减振台座。
水泵减震台座减震形式

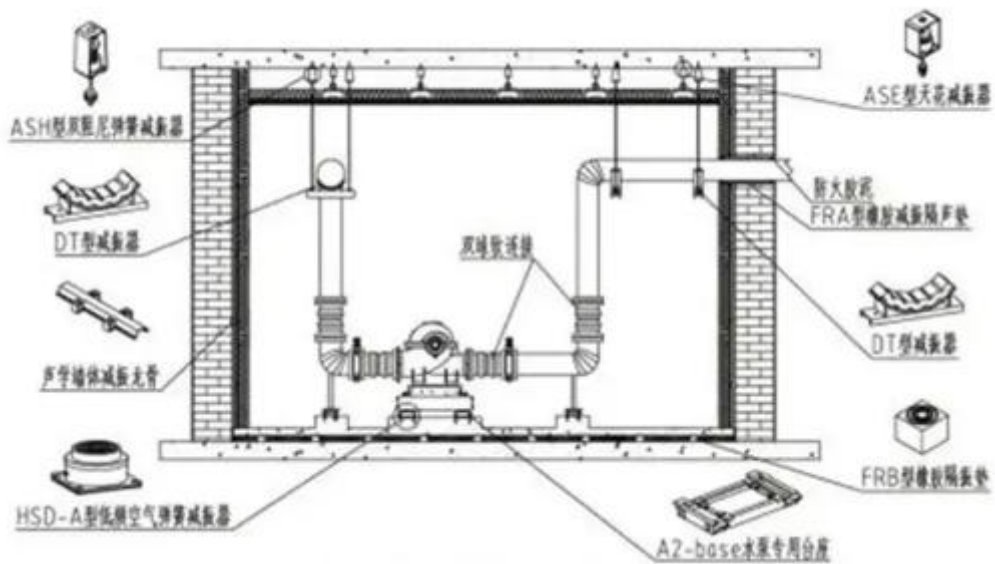

泵房隔振示意图



浮筑基础

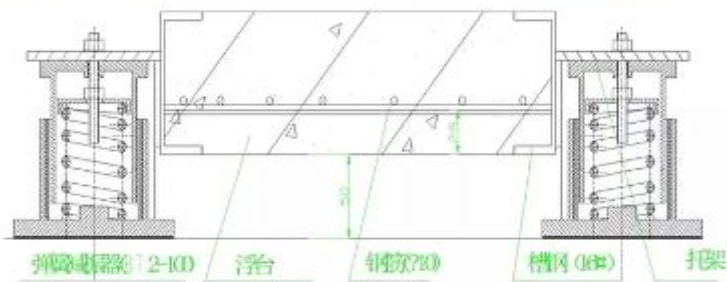

水泵惯性台结构



用混凝土制作水泵惯性块与减震器固定在一起



设备底部橡皮减震垫块设置



金属阻尼减震器



设备底部阻尼弹簧减震器设置



设置在设备底板两侧防位移的“靠山”

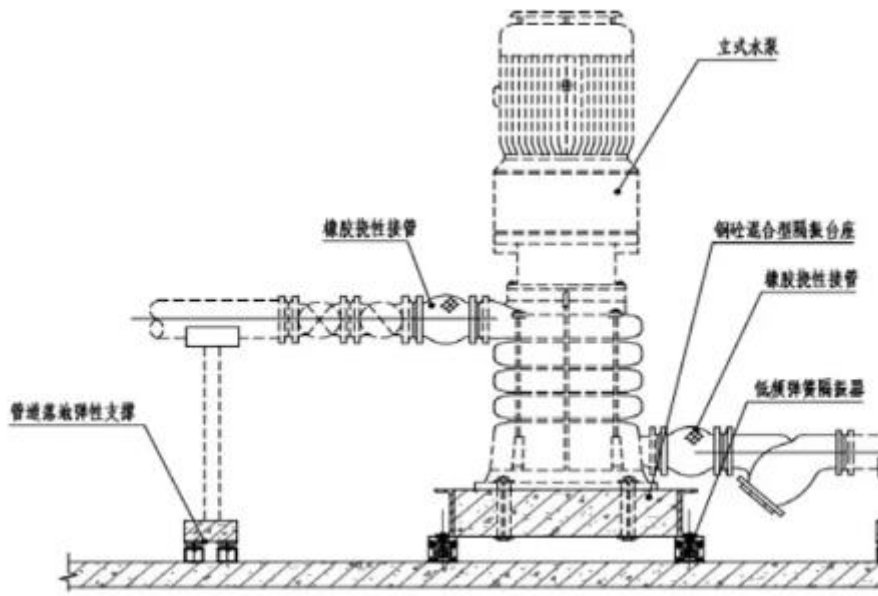

立式水泵隔振处理图



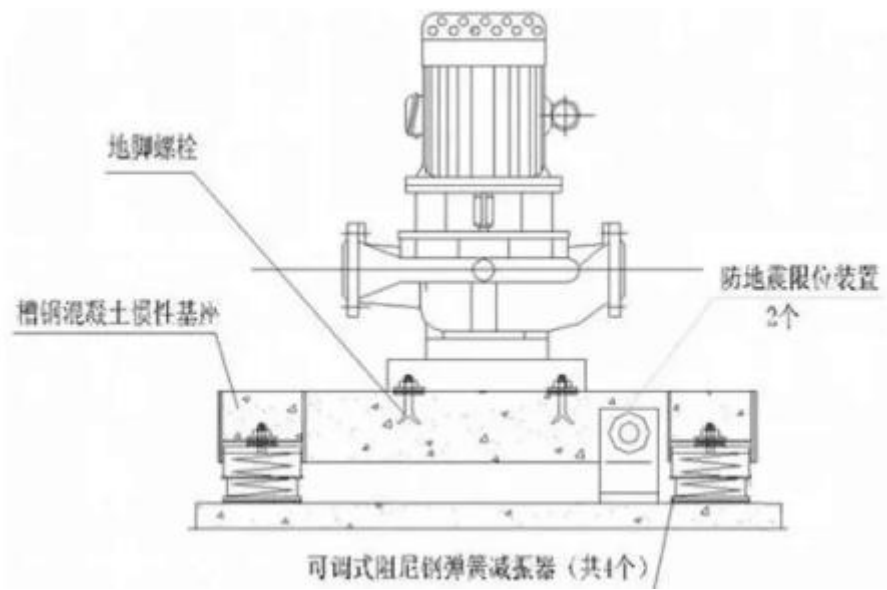

变频供水系统减振处理

2. 空调机组消音隔振处理

吊装式空调机组减振处理

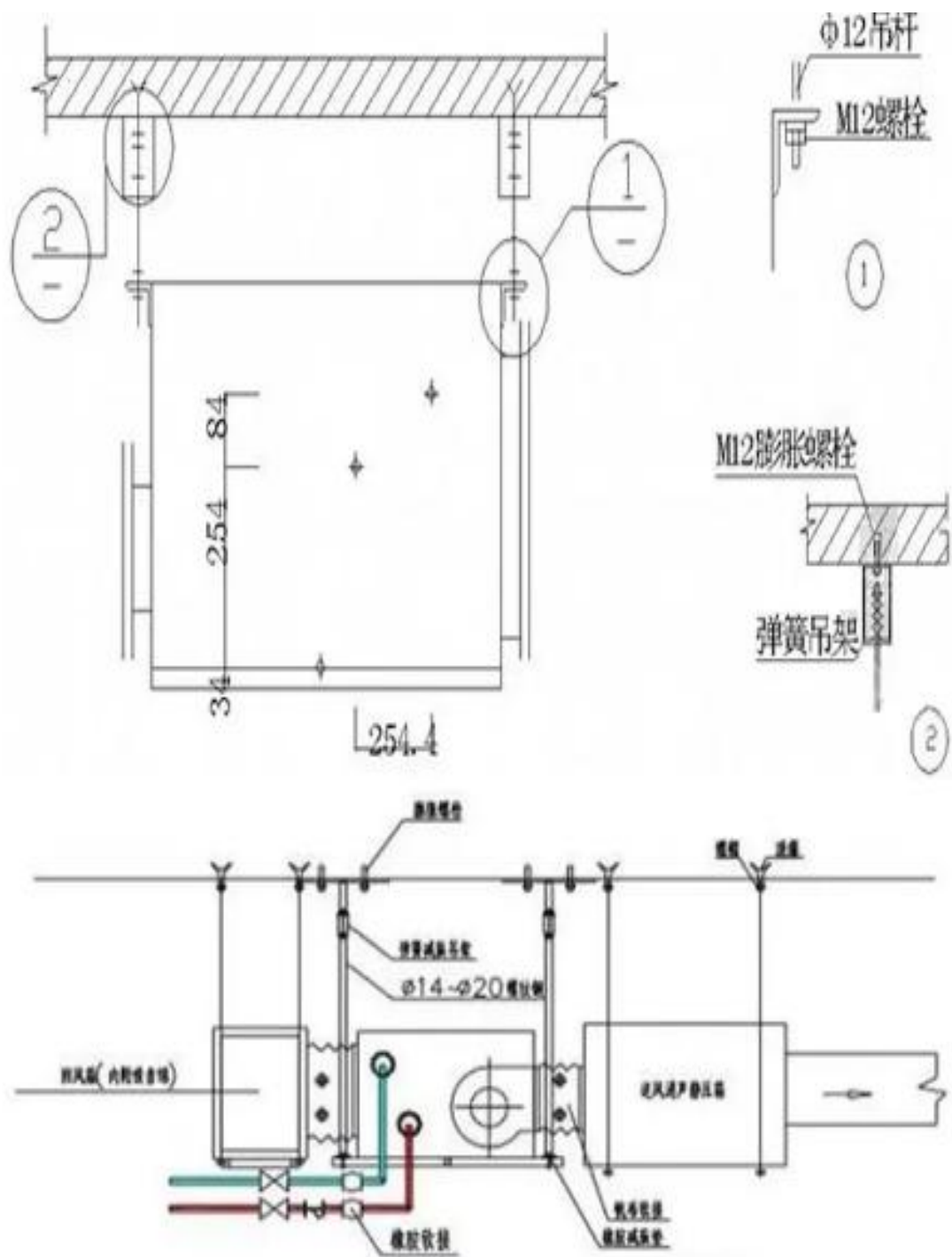

备注：风量大于 8000m³/h 的机组不宜采用吊顶式安装方式，推荐采用落地放置，否则应采取严格的减噪措施。

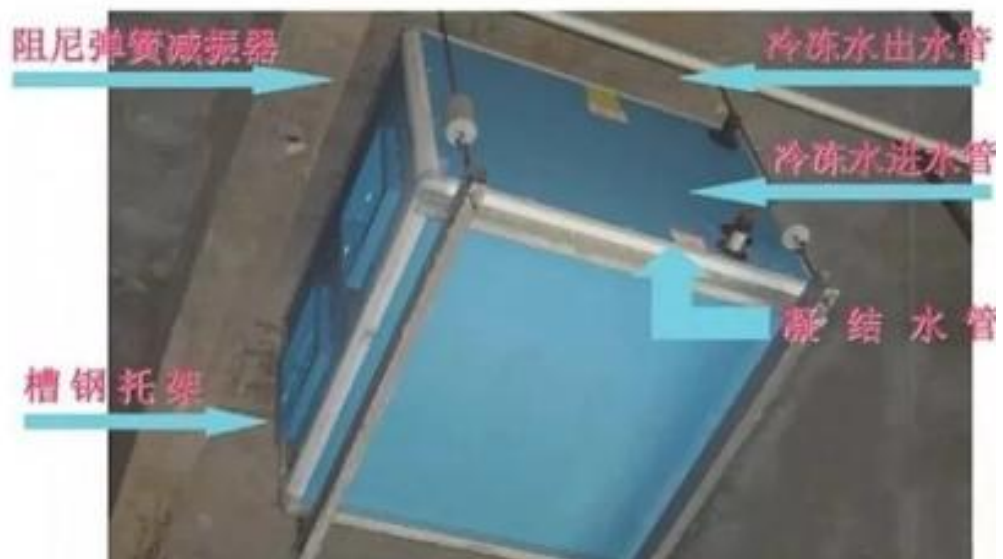



吊装式空调机组减振处理

落地式空调机组减振处理

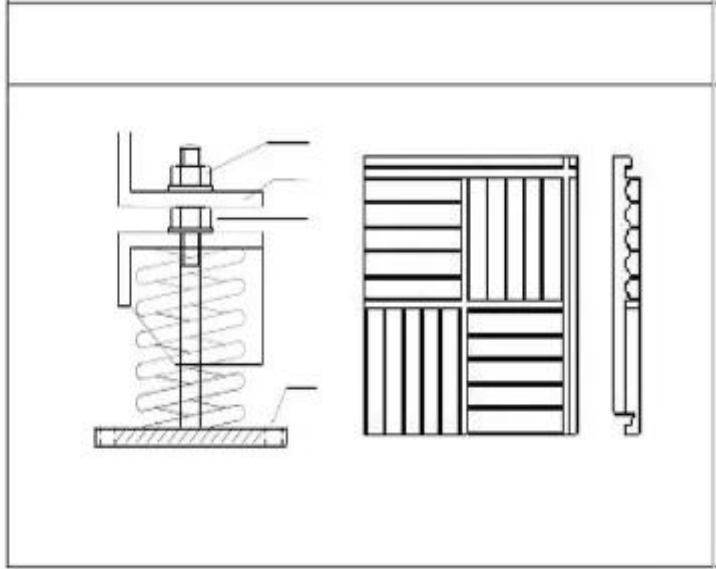
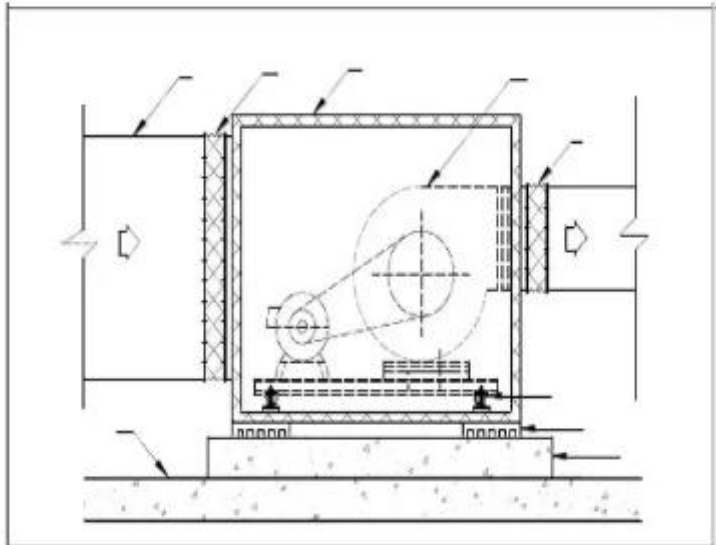

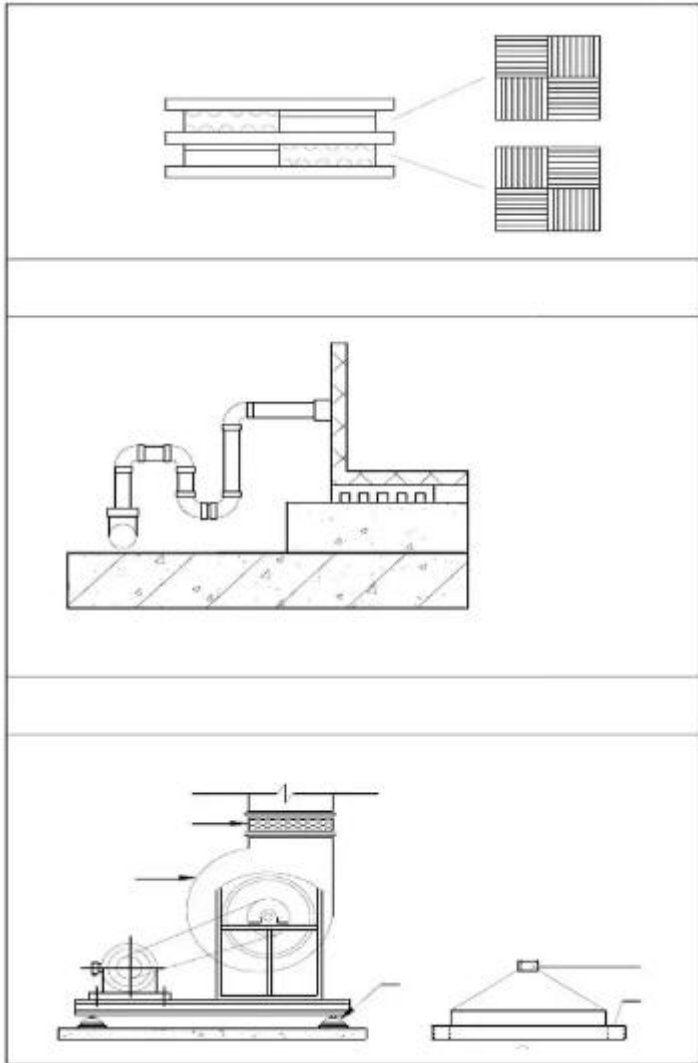

设备底部阻尼弹簧减震器设置

3. 排风排烟机消音隔振处理

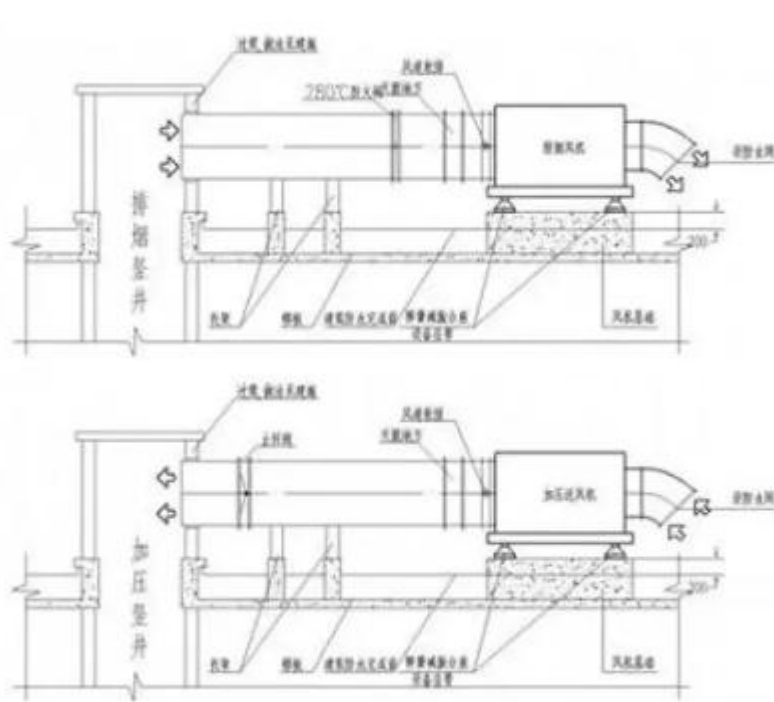

屋顶落地式风机安装示意图



弹簧隔振器



阻尼弹簧减震器

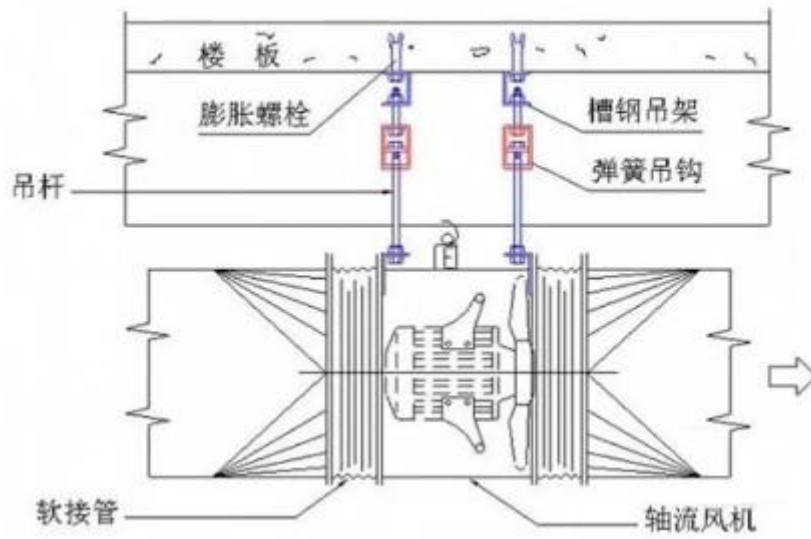

吊式轴流风机安装

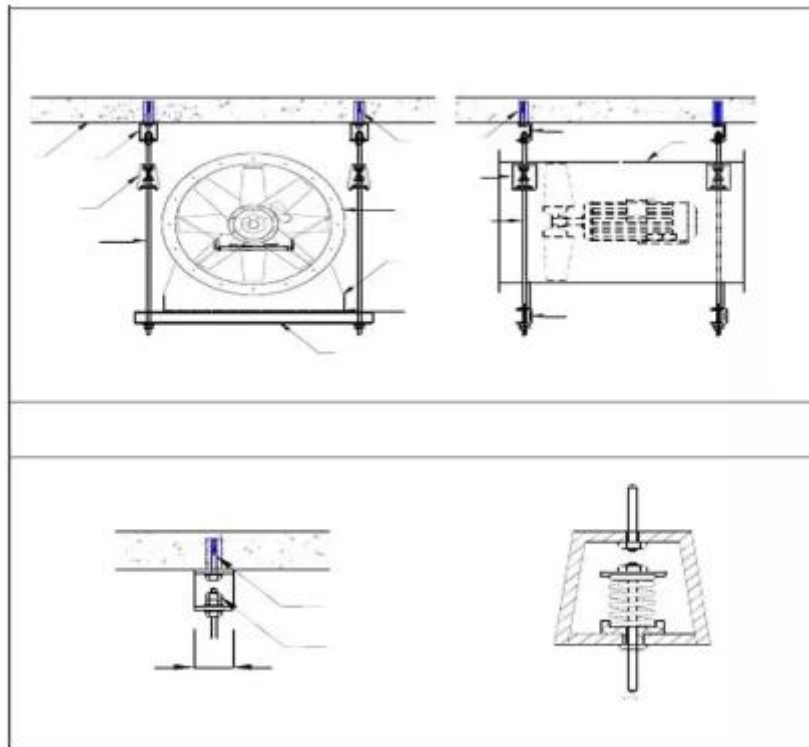

轴流风机防振吊钩

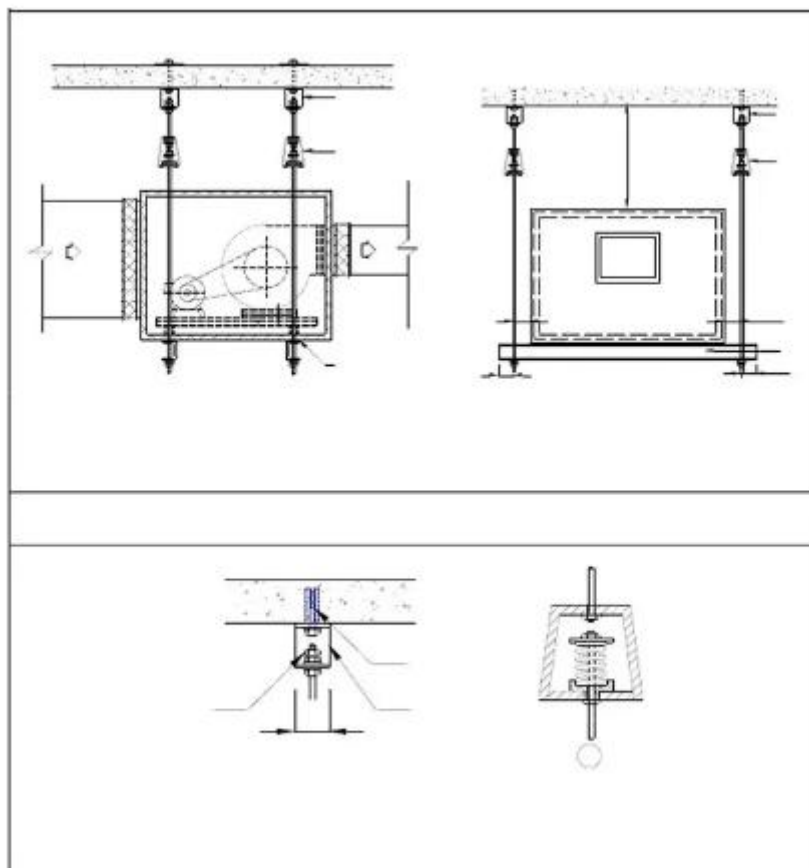

吊式风机箱安装



风机振动噪音处理



为防止轴流风机工作时摆动，用槽钢做成框架固定在楼板上，图为排风兼排烟风机下部设置阻尼弹簧减震器。

4. 冷冻机组消音隔振处理



设备底部金属弹簧减振器设置



冷水机组底座设置弹簧减振器，落地支架应安装在柔性短管的后侧



在弹簧减振器下部设置水平度调整钢板，便于设备一次就位

5. 设备管道减振降噪

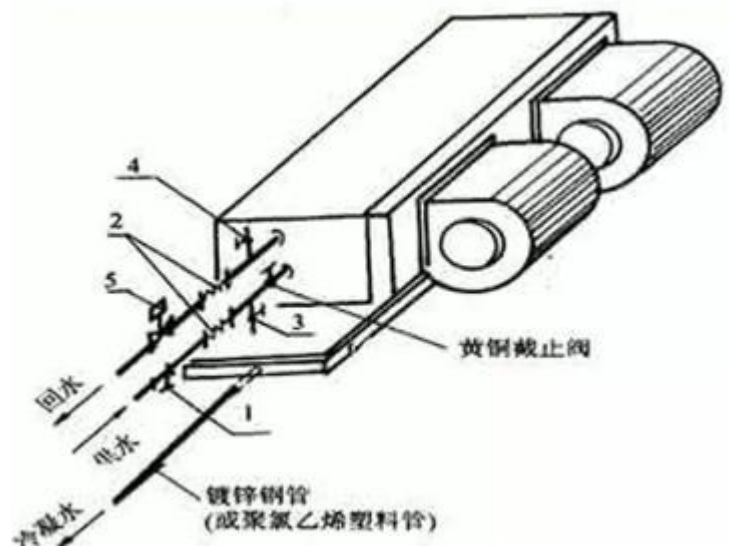

1. 水过滤器；2. 风机盘管专用柔性接头；3. 泄水阀；4. 放空气阀；5. 电动二通阀。

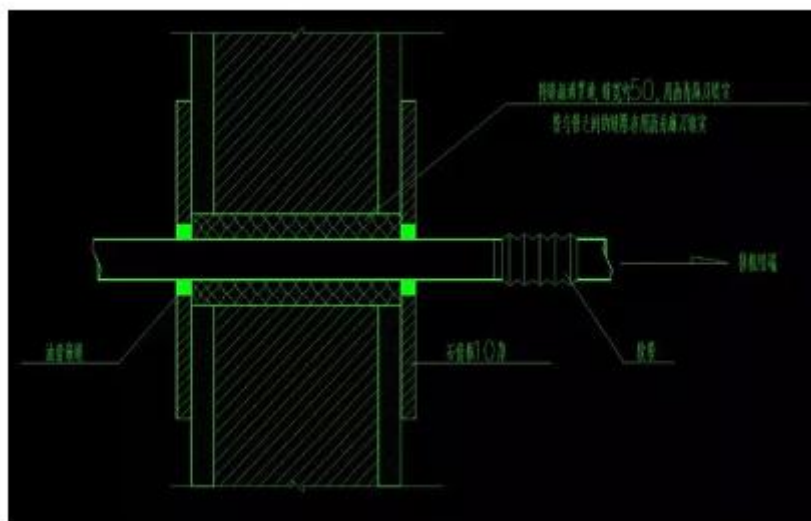

管道穿墙（板）处采用柔性材料填塞套管/管道间缝隙大样

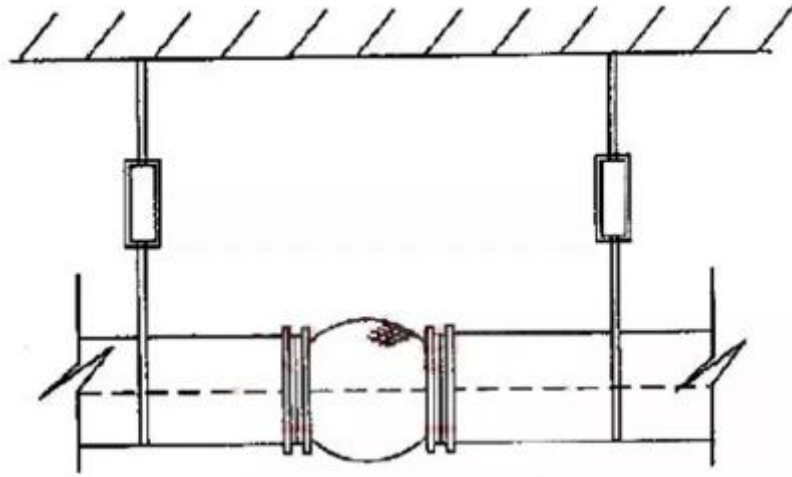

吊装式管道减振



全不锈钢波纹补偿器



穿墙处金属软接

管道管夹消音隔振处理

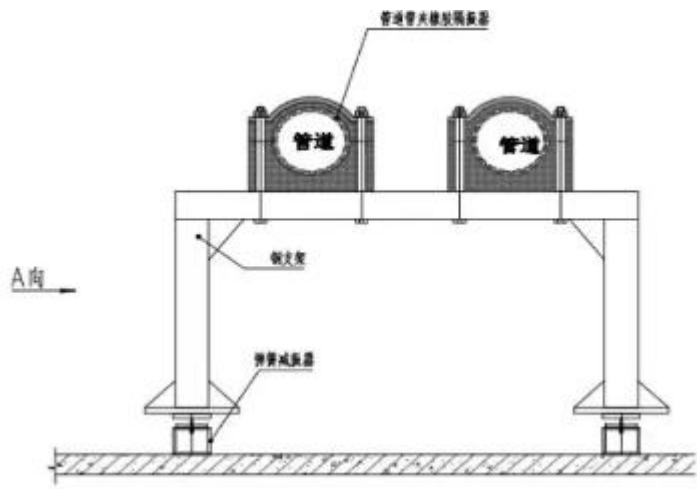

管道落地支撑隔振处理图

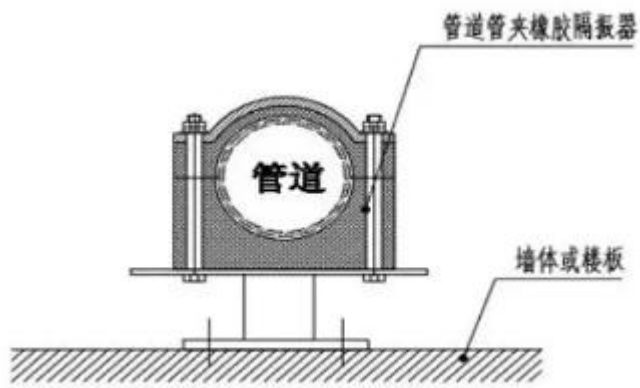

管道隔振处理图（管径小于 150 管道）



立管消音隔振处理

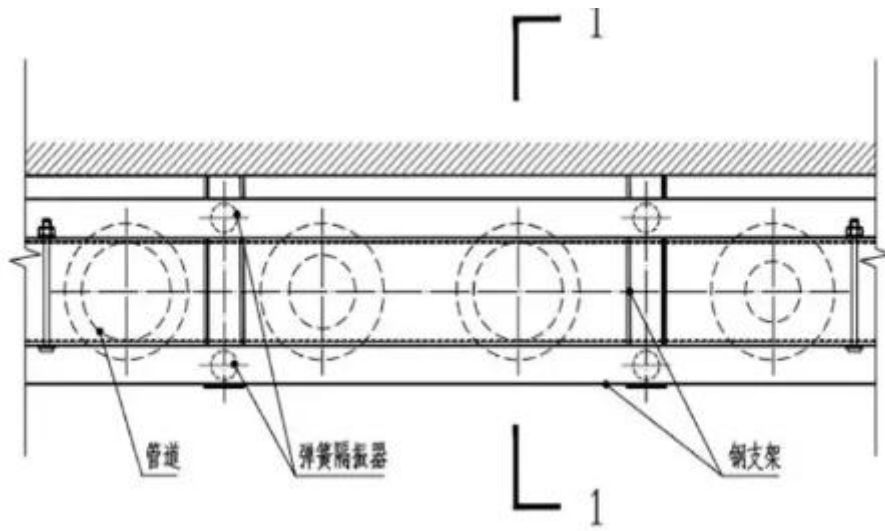

管道隔振处理图（管径大于 150 管道）

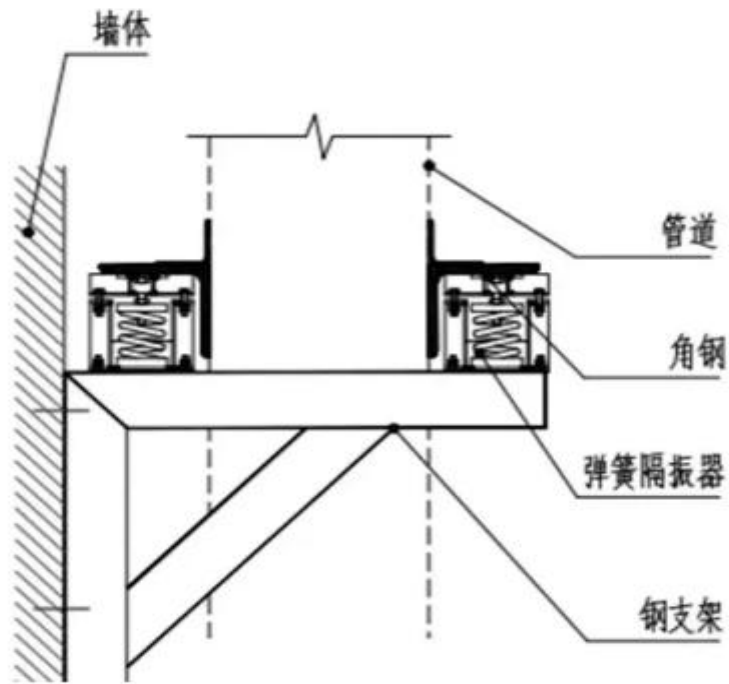

管道落地支撑支架减振处理

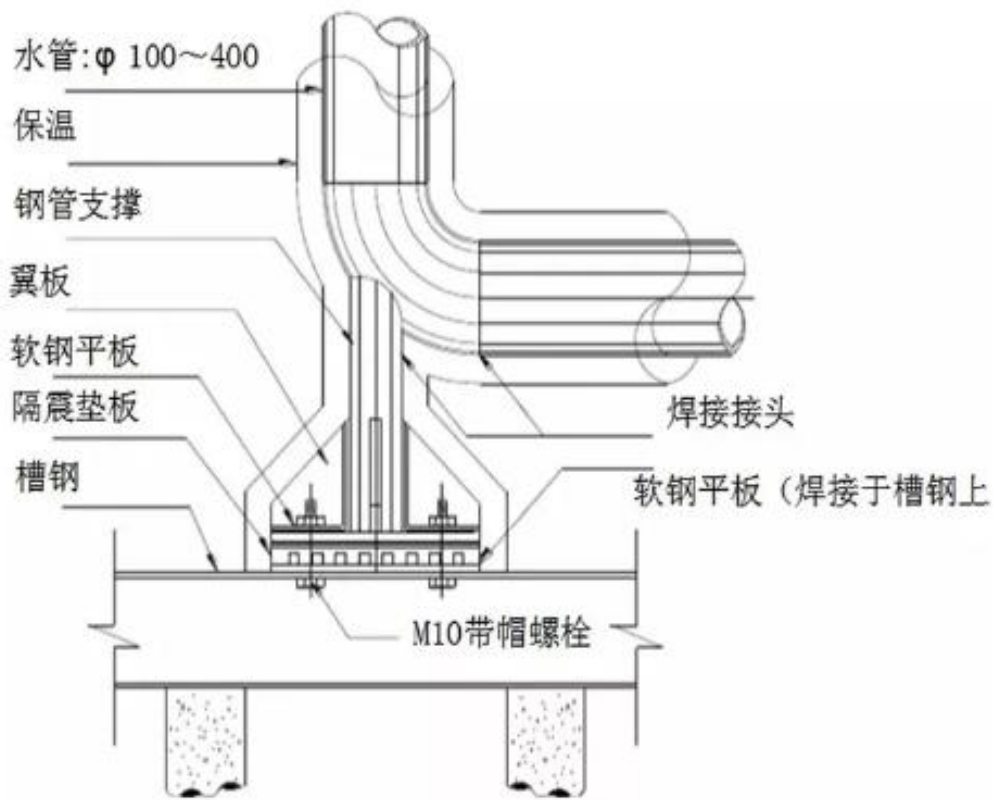

管道消声处理

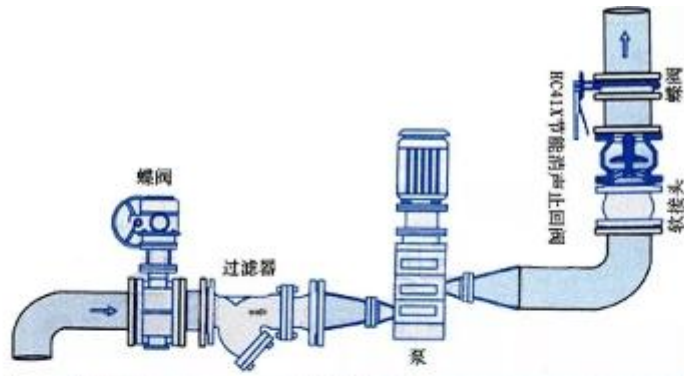

金属软接与金属软管



波纹补偿器和橡胶软接头



管道减振-橡胶减震垫

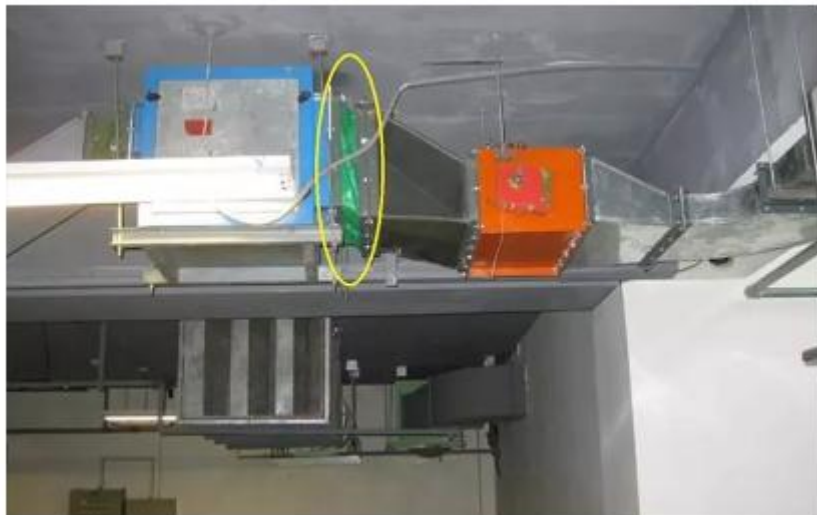

防水帆布接头



风管与风机应采用柔性短管连接

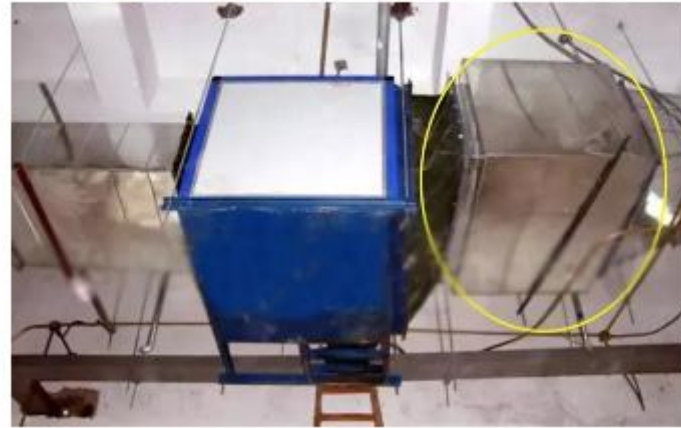
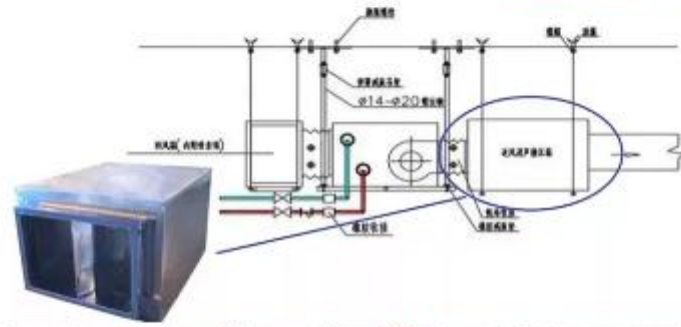
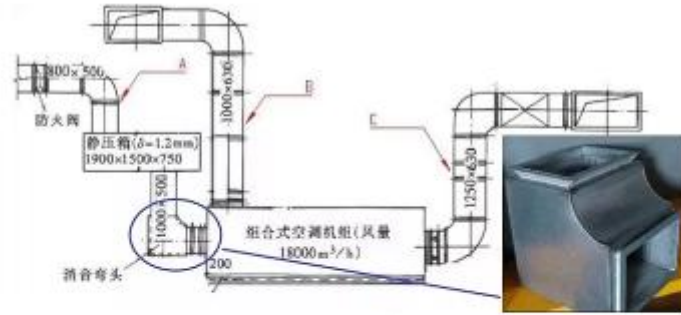

静压箱



冷却塔消声处理

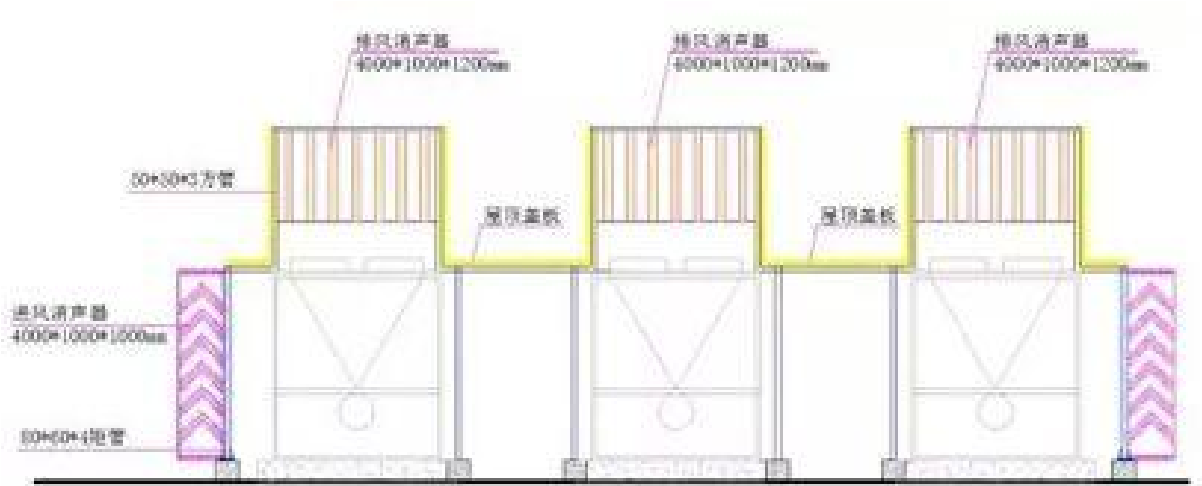

中央空调外机降噪

机电安装工程设计中，对消声减振的具体措施的简要归纳：

- 1.建筑机电工程中，除了对风机、水泵等产生振动的设备设置弹性减振支座外，还应在风机与管路之间采用软管链接，软管宜采用人造材料或帆布材料制作。
- 2.水泵、冷水机组、风机盘管、空调机组等机电设备与水管之间用软管连接，不使振动传递给管路。软管分为橡胶软接管和不锈钢波纹管两类：橡胶软接管隔振减噪的效果很好，缺点是不能耐高温和高压，耐腐蚀性也差。在空调与采暖的水系统中多用橡胶接管；不锈钢波纹管能耐高温、高压和耐腐蚀，但价格较贵，一般用于制冷剂管路的隔振。
- 3.在管路的支吊架、穿墙处，使用非燃软性材料填充做减振处理。

4.空调机组、水泵落地式设备，可直接采用橡胶隔振垫隔振或弹簧复合振器。

5.振动较大的设备（如风机）吊装时，采用减振吊钩。

6.选用高效、低噪声水泵、风机，并使水泵、风机在最高效率点附近运行。

7.按噪声标准控制风管、风口风速，以满足房间噪声要求。

8.设备机房内壁表面贴附吸声材料及吸声孔板，机房门采用消声密闭门，使墙体有吸声能力，等等。