



湖南三一工业职业技术学院  
HUNAN SANY POLYTECHNIC COLLEGE

# 三相异步电动机的点动控制





## 点动控制

常用于机床主轴或工作台的调整；机床的试车、检修等。

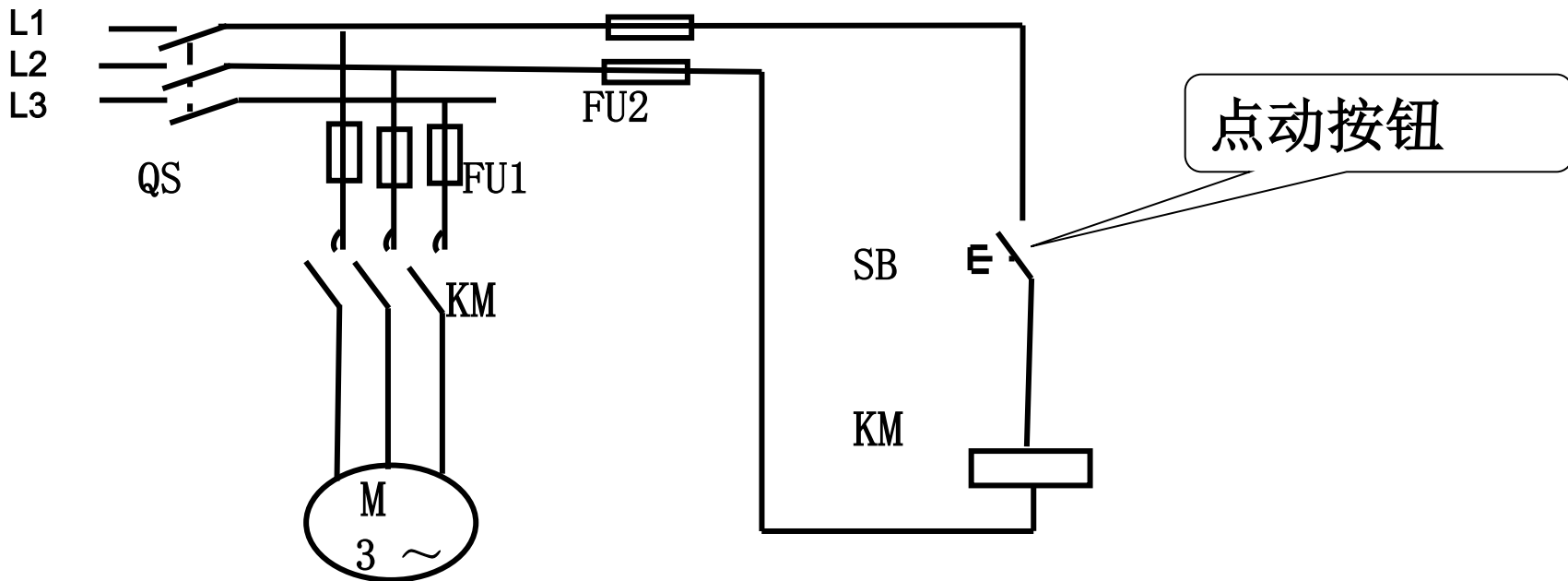

工作过程：先接通电源开关QS

按下**SB** → **KM**线圈得电 → **KM**主触头闭合 → 电动机**M**通电起动。

松开**SB** → **KM**线圈断电 → **KM**主触头复位 → 电动机断电停转



# 1. 点动控制电路

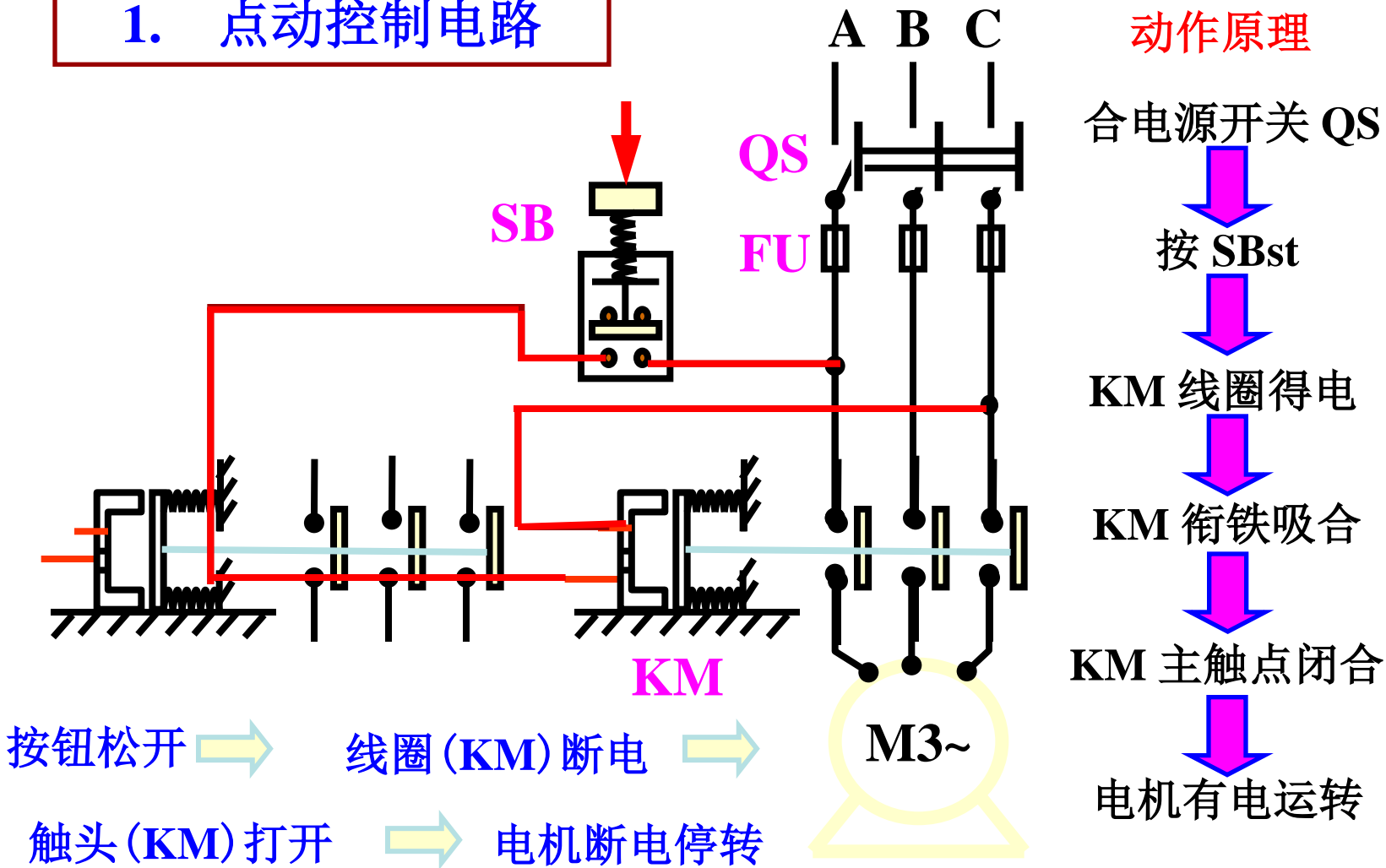



## 电动机点动控制电路原理图

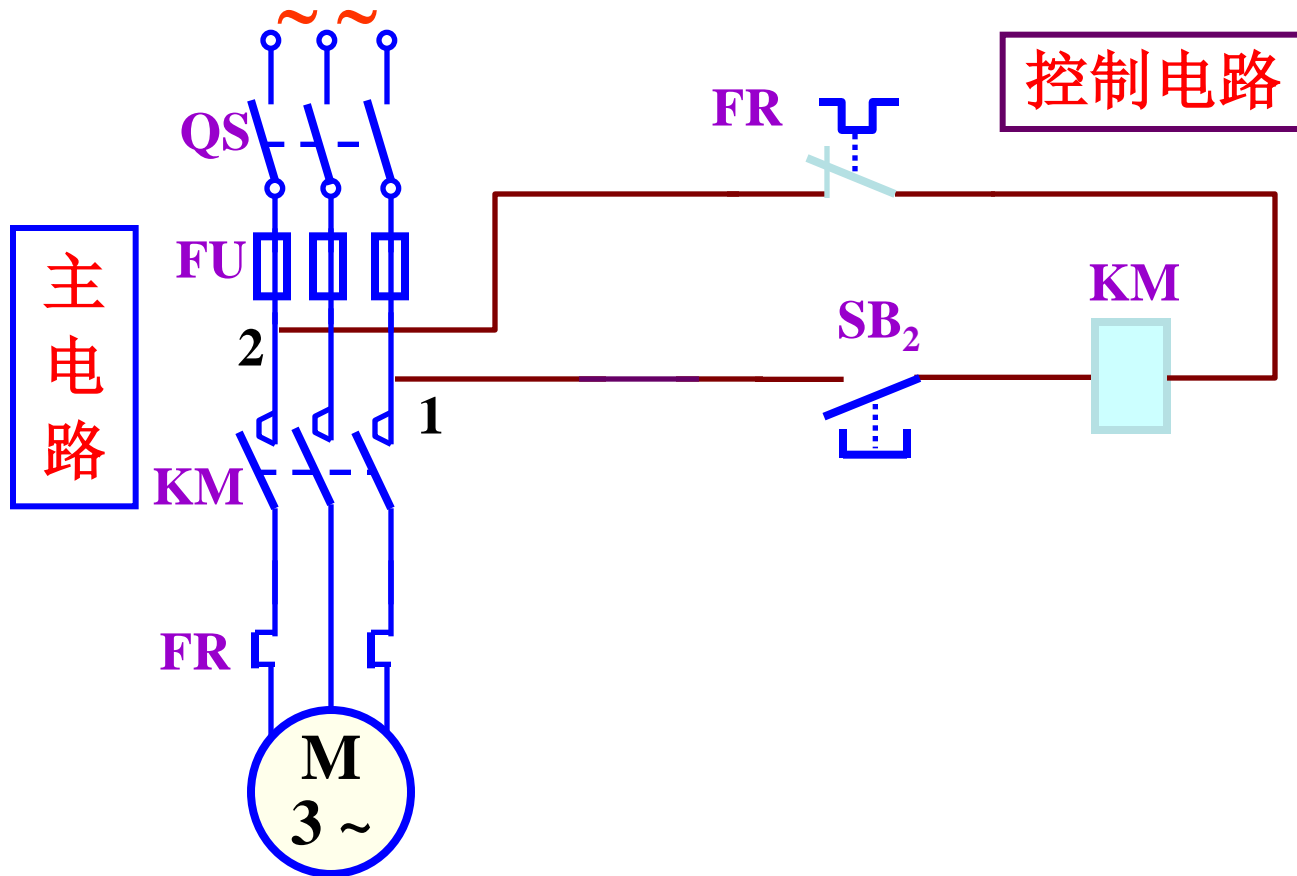



湖南三一工业职业技术学院  
HUNAN SANY POLYTECHNIC COLLEGE

品质改变世界

谢谢大家